



FVL100-DKLOCK

locking tilt and turn window handle

Product information

Code: 1503D065INXX0

Finish: satin stainless steel

UNIT: Piece

Collection: FERROVIA

Designer: Formani

EAN code: 8718009083260

FERROVIA by Formani

The FERROVIA series is a total concept collection consisting of door, window, and furniture fittings.

Finishes

- satin stainless steel
- polished stainless steel

FVL100-DKLOCK

locking tilt and turn
window handle
stainless steel

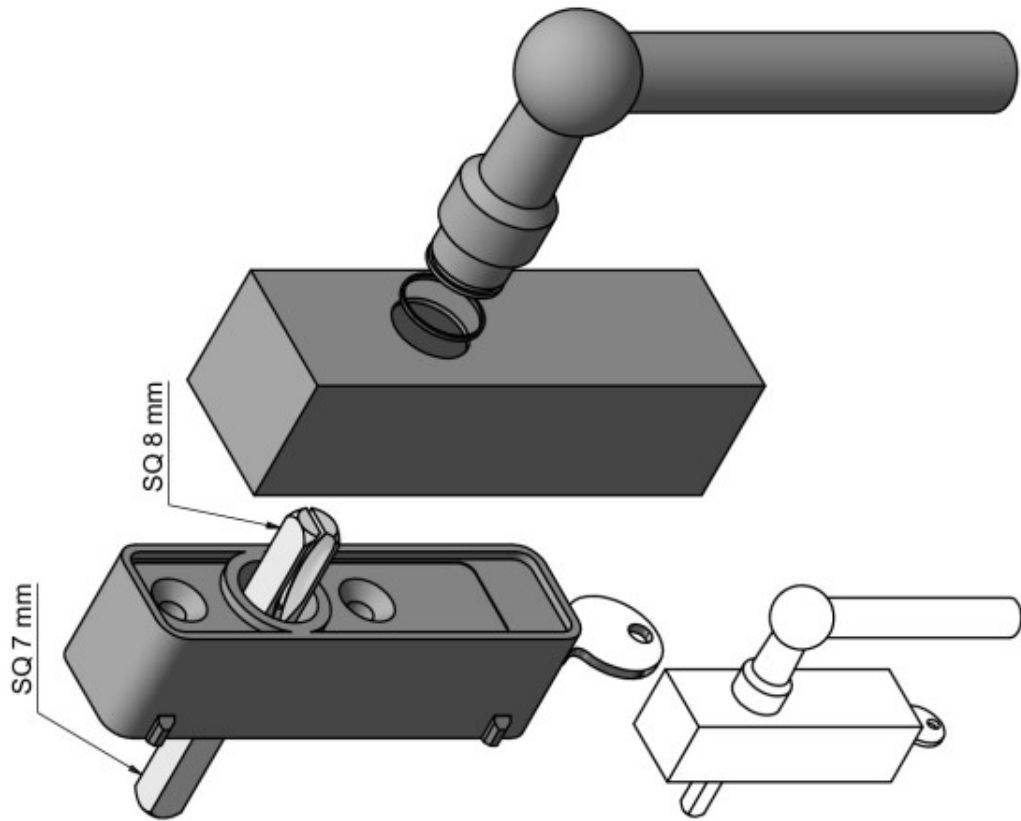
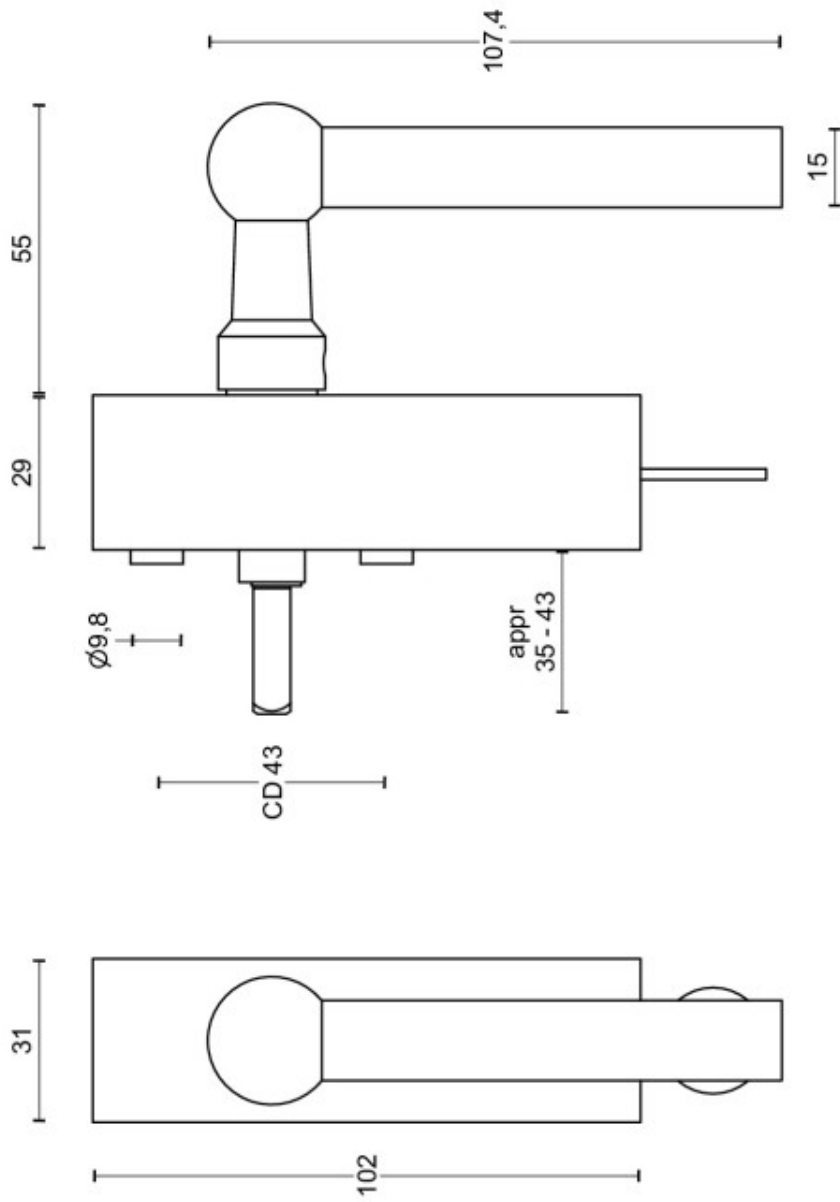

FORMANI®		Part number:	
		FVL100-DKLOCK	
Doc no.: 1503D065 FVL100-DKLOCK V01.dwg		Format: A3	
Drawn by: Christian Brimbois		Creation date: 1-9-2017	
FORMANI HOLLAND B.V. - EUROPA-LAAN 12, 6199 AB MAASTRICHT-AIRPORT NL, T +31 (0)43 308 90 00 INFO@FORMANI.COM FORMANI.COM			

FERROVIA

by Formani

Our FERROVIA hardware series is an ode to the railways of the early twentieth century. Having often been used in first-class train carriages, this particular style of door handle is held up as a piece of understated luxury thanks to its elegant shapes, curves, and clean lines. The design is characterized by its spherical shape that connects the lever to its neck. The 'T-handle' was especially popular in train carriage design at the time, and is still a common design feature in many interiors and exteriors. The FERROVIA hardware series has been modernized and produced from solid stainless steel (available in a matte or polished finish). It concerns a total concept collection, including door, window and cabinet fittings and is complemented by the usual accessories, which enable one uniform style to be applied to all areas within the home or any other property.

FERROVIA

by Formani

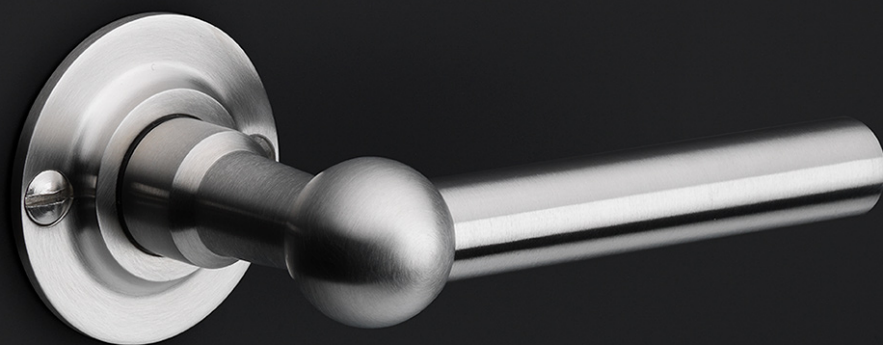

FORMANI®

Brand story

FORMANI has evolved considerably over the last few decades – from a Dutch family business to an internationally renowned designer brand, from door handles to total design concepts, from product development to collaborations with world-class designers. It was an evolution driven by pure ambition and courage. Our motto, ‘Obsessed with details’, epitomizes everything we do, from product to process, from strategy to service. Because it is these details that make the difference between good and perfect. At FORMANI, good is the enemy of great.

Formani Holland b.v.
Europalaan 12
6199 AB
Maastricht-Airport

T: +31(0)43 308 9000
E: info@formani.com

Chamber of Commerce:
146 27 479

FORMANI®