



OH102DKLOCK

locking tilt and turn window handle

Product information

Code: 3803D023INXX0

Finish: satin stainless steel

UNIT: Piece

Collection: CONE

Designer: Osiris Hertman

EAN code: 8718009406595

CONE by Osiris Hertman

The CONE series is a total concept collection consisting of door, window, and furniture fittings.

Finishes

- satin stainless steel
- PVD satin black

CONE OH102-DKLOCK

locking tilt and turn
window handle
stainless steel

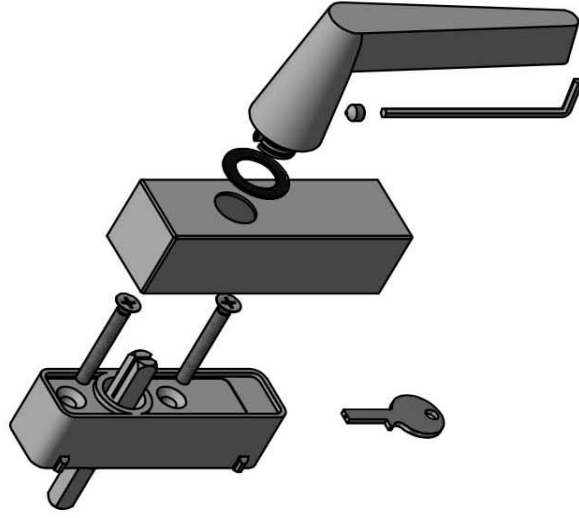
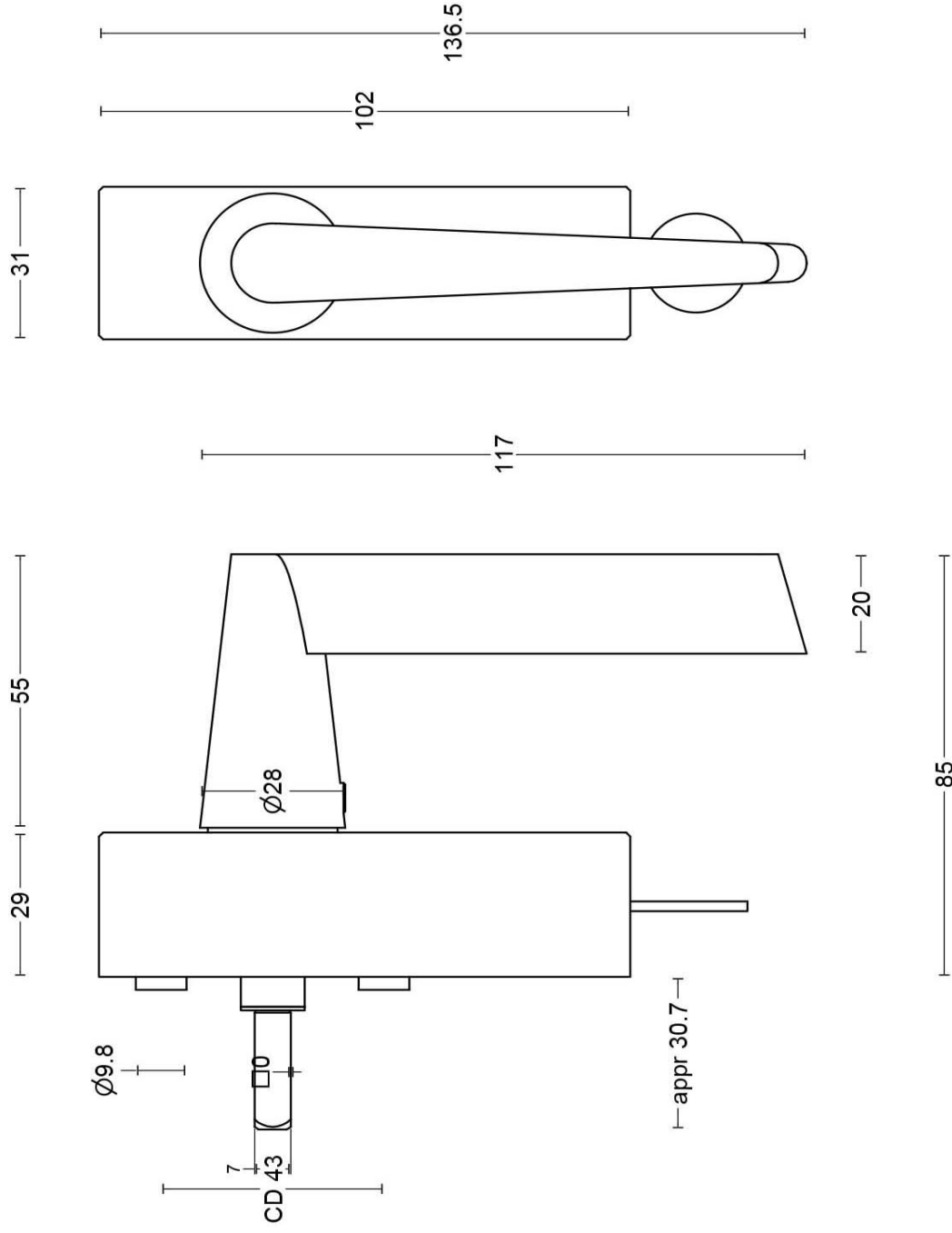

FORMANI® FORMANI HOLLAND B.V. EUROPA LAN 12 6169 AB MAASTRICHT-AIRPORT NL T +31 (0)43 308 90 00 INFO@FORMANI.COM WWW.FORMANI.COM	Type :	CONE OH102-DKLOCK	Version: V01
	Formani filename: 3603D023_OH102-DKLOCK_V01.dwg	Description:	locking tilt and turn window handle stainless steel
Drawn by: Christian Brimbois	Format A3		
Creation date: 8-3-2021			

CONE

by Osiris Hertman

The CONE door handle, inspired by the handle on a safe, is characterized by its elegance and timeless aesthetic. The neck of the door handle is tapered, resulting in its characteristic conical shape. The rosette-less design also creates the allusion of a floating door handle. The door handle is manufactured as one piece, making it a technical masterpiece, especially with the extremely high-standard finish applied. The seamless design imbues a space with a sense of tranquillity while substantially enhancing the overall aesthetics. The CONE door handle has won the 2021 Red Dot Design Award in the 'Product Design' category. The Jury commented: 'The design of the CONE door handle combines strictly minimalist design with sophisticated manufacturing quality to produce an expressive unit'. The winning CONE door handle is part of the total concept collection consisting of door, window, and furniture fittings as well as accessories. The CONE series is available in two finishes: our latest PVD satin black and satin stainless steel.'

CONE

by Osiris Hertman

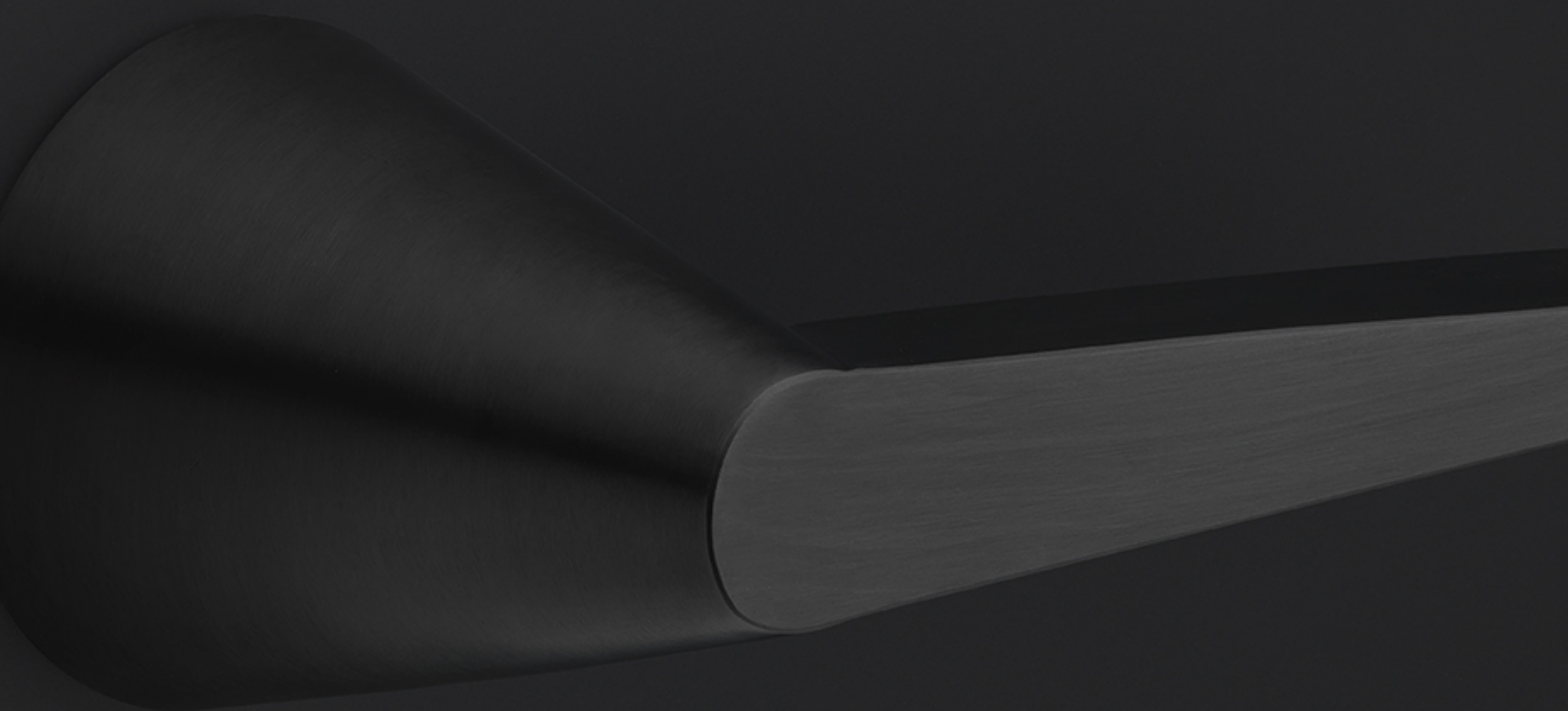

FORMANI®



Osiris Hertman

Tillburg, 1972

Design philosophy: I like to incorporate the landscape in my interiors; the influence of nature is essential. Basically, you can learn everything through nature: the warmth of clothing, the softness that is concealed within hard materials, the flexibility of things, the cohesiosn. Every last thing harmonises with everything else.

‘Osiris Hertman strives to create harmony between architecture and interior design. By working, as much as possible, with natural light in combination with carefully chosen traditional, intense, and dark materials, Hertman always finds the balances between luxury and tranquillity whether subdued or not. Details are essential to this balance. They are also the inspiration for the CONE hardware collection. A door handle gives you access to something precious and could therefore be thought of as a modest but displayed ornament. The simple door handle can bring your attention back to the present. The unique design was inspired by the handle on a safe. The CONE door handle’s technical perfection, and quality ensure unity, balance, and functionality. This co-creation fits perfectly with the design

FORMANI®

philosophy of both Osiris Hertman and FORMANI.'

Formani Holland b.v.
Europalaan 12
6199 AB
Maastricht-Airport

T: +31(0)43 308 9000
E: info@formani.com

Chamber of Commerce:
146 27 479

FORMANI®

Brand story

FORMANI has evolved considerably over the last few decades – from a Dutch family business to an internationally renowned designer brand, from door handles to total design concepts, from product development to collaborations with world-class designers. It was an evolution driven by pure ambition and courage. Our motto, ‘Obsessed with details’, epitomizes everything we do, from product to process, from strategy to service. Because it is these details that make the difference between good and perfect. At FORMANI, good is the enemy of great.
